

primus®

GET AHEAD IN LAUNDRY+



FXB180 | FXB240 | FXB280 BARRIER WASHER-EXTRACTORS



TOUCH CONTROL AVAILABLE
Multilingual user-friendly 7"
touch control



CLOUD-BASED PLATFORM
to easily monitor your laundry
everywhere and at any time



AUTOMATIC WEIGHING SYSTEMS
Automatically adapts amount of water
and detergent based on the wash load



IMPROVED DURABILITY
for your peace of mind with a 3-year
warranty

FEATURES & BENEFITS

Features

- Freestanding, high spin, inverter drive
- Stainless steel cabinet, drum and tub
- Patented soap hopper
- Easy access to all important parts
- Large door opening for easy loading & unloading
- Automatic drum positioning
- Golden Lock - patented inner door lock mechanism
- Large drain valve (Ø 76 mm)

Options

- Liquid soap connection and pumps
- Water recovery kit and sample tap
- Second Display on the clean side
- Steam heating version
- End of cycle extra signalling (traffic light + siren)
- Lateral drain
- 3rd water inlet

Control

- XControl FLEX PLUS – fully programmable and customizable cycles 7" touch screen.
- User-friendly screen with operating instructions built in as part of the control
- Complete control content available in 34 languages

SPECIFICATIONS

TYPE		FXB180	FXB240	FXB280
INNERDRUM				
Capacity 1:09	kg (lb)	20(44)	27(60)	31(68)
Capacity 1:10	kg (lb)	18(40)	24(53)	28(62)
Volume	litres	180	240	280
Diameter	mm	750	750	750
DRUM SPEED				
Wash	rpm	42	42	42
Extraction	rpm	939	939	914
G-FACTOR		370	370	350
HEATING				
Electricity	kW	12 - 18	18	21,9
Steam	bar	3 - 8	3 - 8	3 - 8
Sound pressure level	dB (A)	< 67	< 68	< 70
Water valves connection	BSP	3 x 3/4"	3 x 3/4"	3 x 3/4"
Water pressure	kPa	100-600	100-600	100-600
Rec. water pressure	kPa	300-500	300-500	300-500
Water inlet	l/min	20	20	20
Drain valve	outer Ø mm	76	76	76
Flow amount with drain valve	l/min	210	210	210
Steam valve connection	BSP	1/2"	1/2"	1/2"
Steam pressure	kPa	100-800	100-800	100-800
DIMENSIONS				
Size H×W×D	mm	1455×900×1145	1455×1020×1145	1455×1130×1145
Net weight	kg	430	460	490
TRANSPORT DATA				
Packed H×W×D	mm	1610×1010×1235	1610×1130×1235	1610×1240×1235
Gross weight	kg	485	515	550

DIMENSIONS

	A	B	C	D	E	F	G	J	L	M	T	U	V	Y
FXB180	1025	1127	655	1150	202	1423	1455	277	850	900	312	376	1325	1145
FXB240	1025	1127	675	1150	202	1423	1455	277	970	1020	312	496	1325	1145
FXB280	1025	1127	670	1150	202	1423	1455	277	1080	1130	312	496	1325	1145

height
width
depth

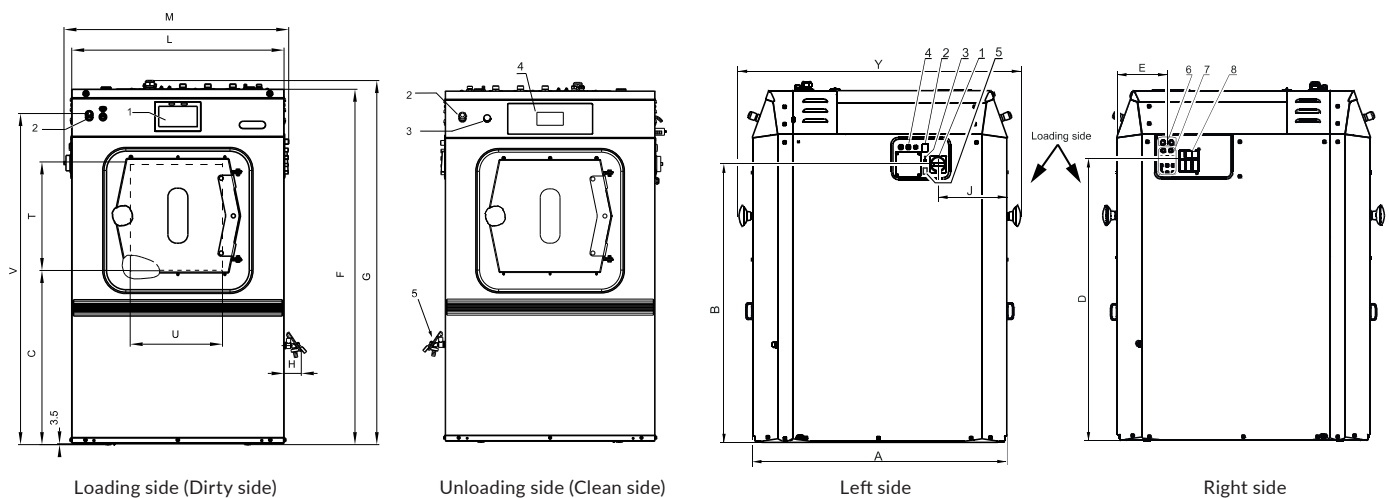

- | | | | |
|--|--------------|---|--|
| 1. Control panel | 5. request) | 1. Main switch | 5. PC programming connection (on request) |
| 2. Emergency stop button "CENTRALSTOP" | 5. Water Tap | 2. Heating change-over switch (electric heating, steam heating), (on request) | 6. Inlet of water from the recycle (external diameter 0.75 in. [19mm]) |
| 3. Signal of machine running | | 3. USB port, (on request) | 7. Air relieve |
| 4. Display on clean side (on request) | | 4. Fuses | |